

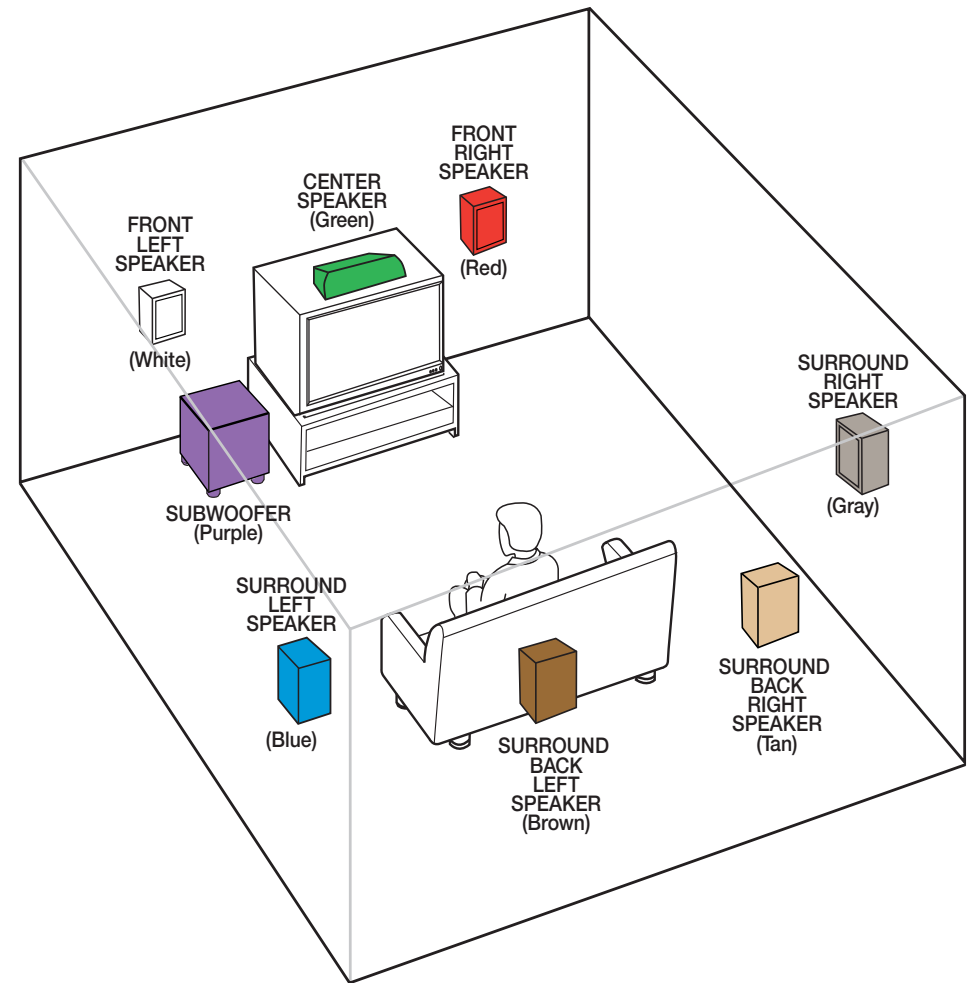











Thank you for purchasing a Harman Kardon® AVR 340. This Quick-Start Guide will help you with a basic system installation. For detailed information on any step in this Guide, please refer to the pages referenced in the Owner's Manual. We strongly recommend that you read the Owner's Manual for complete details on how to install, configure and operate the AVR 340, as well as for the important safety information it contains.

**Figure 1 – Speaker Placement**

The colors shown for each speaker correspond to the matching output terminal connection on the back of the AVR 340 (see page 8).



Step 1. Place your speakers in the listening room (see pages 19–21).

Connections Color Guide		
Audio Connections	Left	Right
Front		
Center		
Surround		
Subwoofer		
Surround Back		
Digital Audio Connections		
Coaxial		
Optical		
Video Connections		
Composite		
S-Video		

Match the colored jacks on the AVR 340 to the appropriate jacks on your source equipment or speakers. The colors are standardized, but not all equipment or connectors use them.

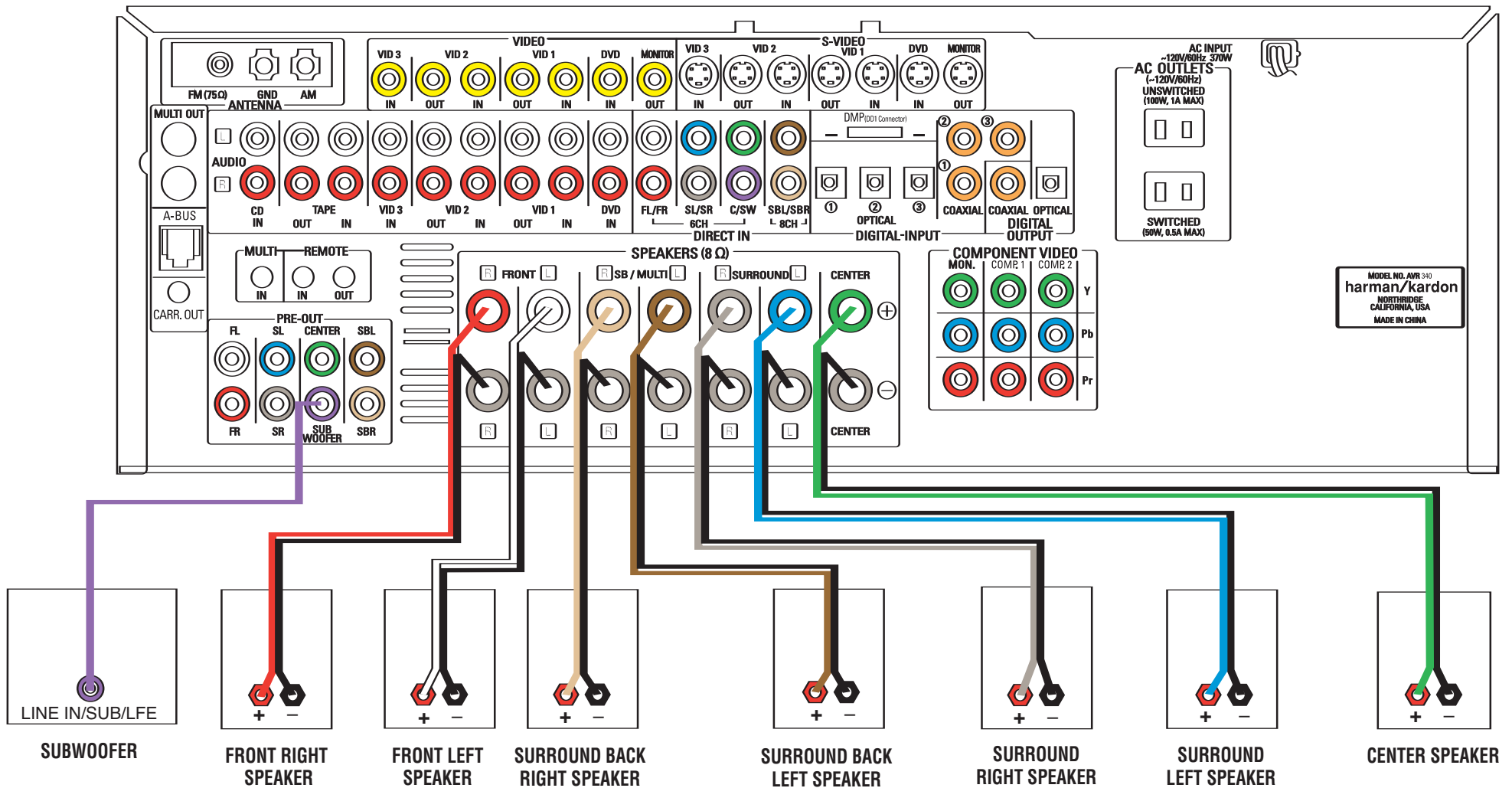

Figure 2 – Speaker Connections

Step 2. Connect the speakers to the receiver: red (+) on speaker to colored (+) on receiver, and black (-) to black (-) (see page 16).

Step 3. Connect the Subwoofer Pre-Out jack to the Line-In jack on your subwoofer (see page 16). You may adjust the settings on the subwoofer later as needed.

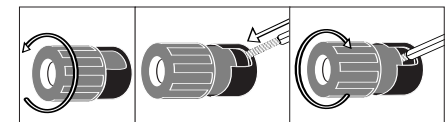

Figure 3 – How to Use the Binding-Post Speaker Terminal

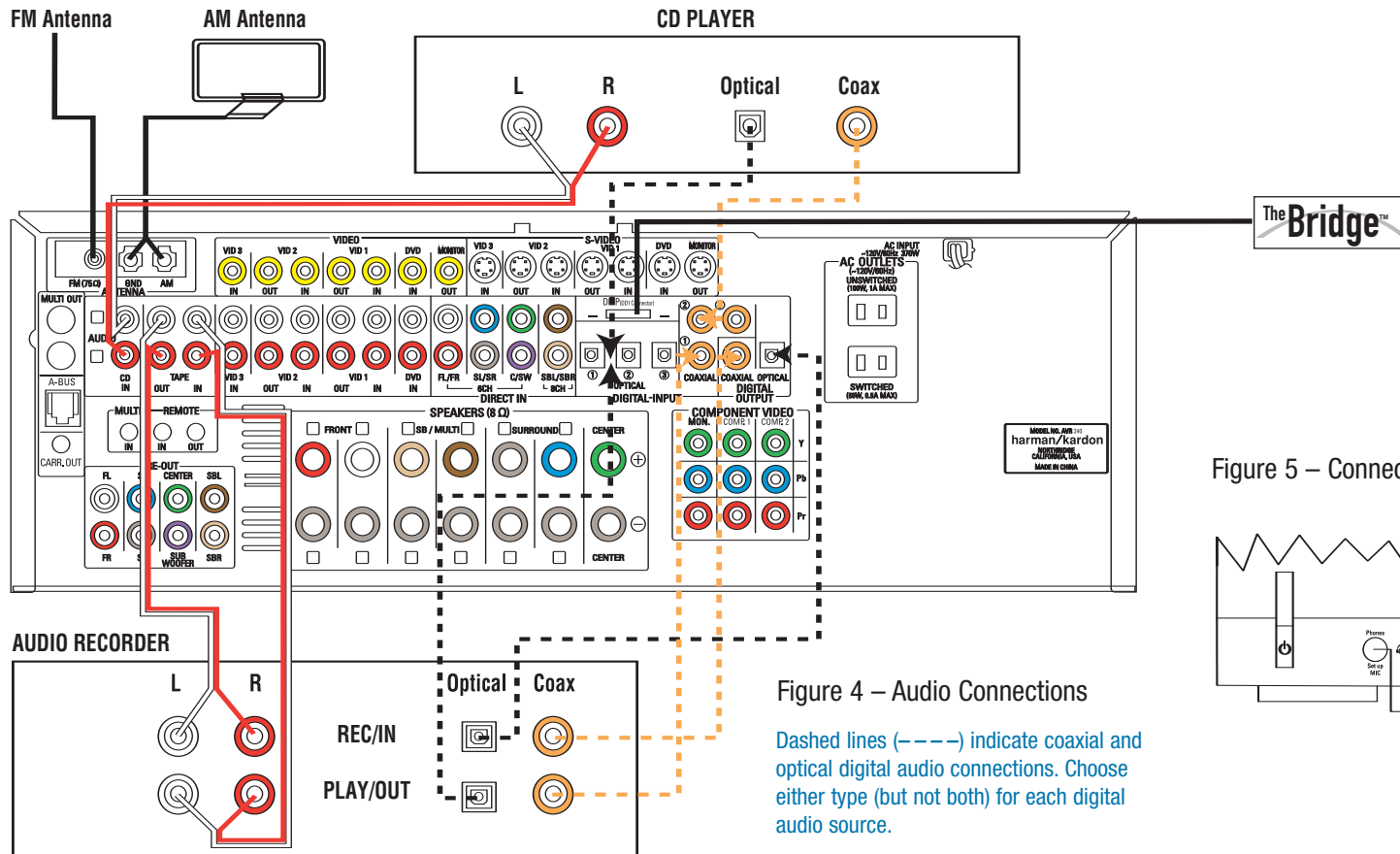
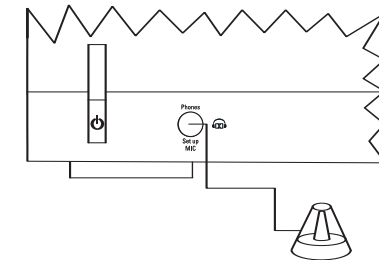

Figure 4 – Audio Connections

Dashed lines (---) indicate coaxial and optical digital audio connections. Choose either type (but not both) for each digital audio source.

Figure 5 – Connecting EzSet/EQ Microphone



Step 4. Connect AM and FM antennas as shown above (see page 16).

Step 5. Connect source components, as shown in Figures 4 and 6 and the Device Connection Options chart on the back of this Guide (see pages 16–17).

**AUDIO connections:** Right channel (red) on source to right (red) on AVR, and left channel (white) on source to left (white) on AVR.

**DIGITAL AUDIO connections, if available:** Choose either coax (orange) to coax (orange) OR optical to optical for each device.

The Coax 1 input defaults to the DVD player, and the Optical 1 input defaults to Video 2 (Cable/Sat), but either may be reassigned. Assign the other digital inputs as appropriate for your equipment (see Step 7).

**VIDEO connections:** Choose component (Y/Pb/Pr – green/blue/red), composite (yellow) or S-video (4-pin) for each video source. Connect the Video Monitor outputs to your video monitor (TV). If component video is available, only that monitor output is needed (see page 17). The Component Video 1 input defaults to any of the DVD, tuner, CD or tape sources. The Component Video 2 input defaults to

any of the Video 1, 2, 3 or 4 sources, or the 6-/8-channel direct inputs. However, either component video input may be reassigned using the Input Setup menu. Switch your TV set's input to match the type of video used for the currently selected source.

**The Bridge:** Make sure the AVR 340 is turned off, then connect the optional The Bridge to the DMP connector. Dock your compatible iPod® (not included) in The Bridge.

Step 6. Plug all components into AC power outlets. The outlets on the back of the AVR 340 should be used *only* for low-current products, such as CD or DVD players, and the total should not exceed 100 watts.

#### Basic Receiver Configuration

Step 7. **Select digital inputs:** If your DVD is connected to Coax 1, and your cable or satellite TV box (Video 2 source) is connected to Optical 1, no adjustment is needed. For any other digital-device connections, use the on-screen Input Setup menu, or the front-panel Digital Select and arrow buttons to select digital input (see pages 22, 38).

Step 8. **Select a surround mode:** Press the Surround Mode button on the front panel to select Dolby® Pro Logic® II – Movie. (You may select other modes later as you become familiar with the AVR 340; see pages 23–25 and 35–41.)

Step 9. **Use EzSet/EQ to configure and optimize your system:** Plug the EzSet/EQ microphone into the front-panel Headphones jack (Figure 5). Place the microphone at your normal listening position. If desired, the microphone may be attached to a standard camera tripod using the threads on the bottom of the microphone. Activate EzSet/EQ using the on-screen menu system (see pages 25–27). As EzSet/EQ senses the output of each speaker, you will hear loud test signals. When the on-screen menu indicates that setup is complete, your system is adjusted for output levels, delay times, speaker settings and room equalization. Unplug the microphone and store it for future use.

Step 10. Your system is configured – sit back and enjoy!

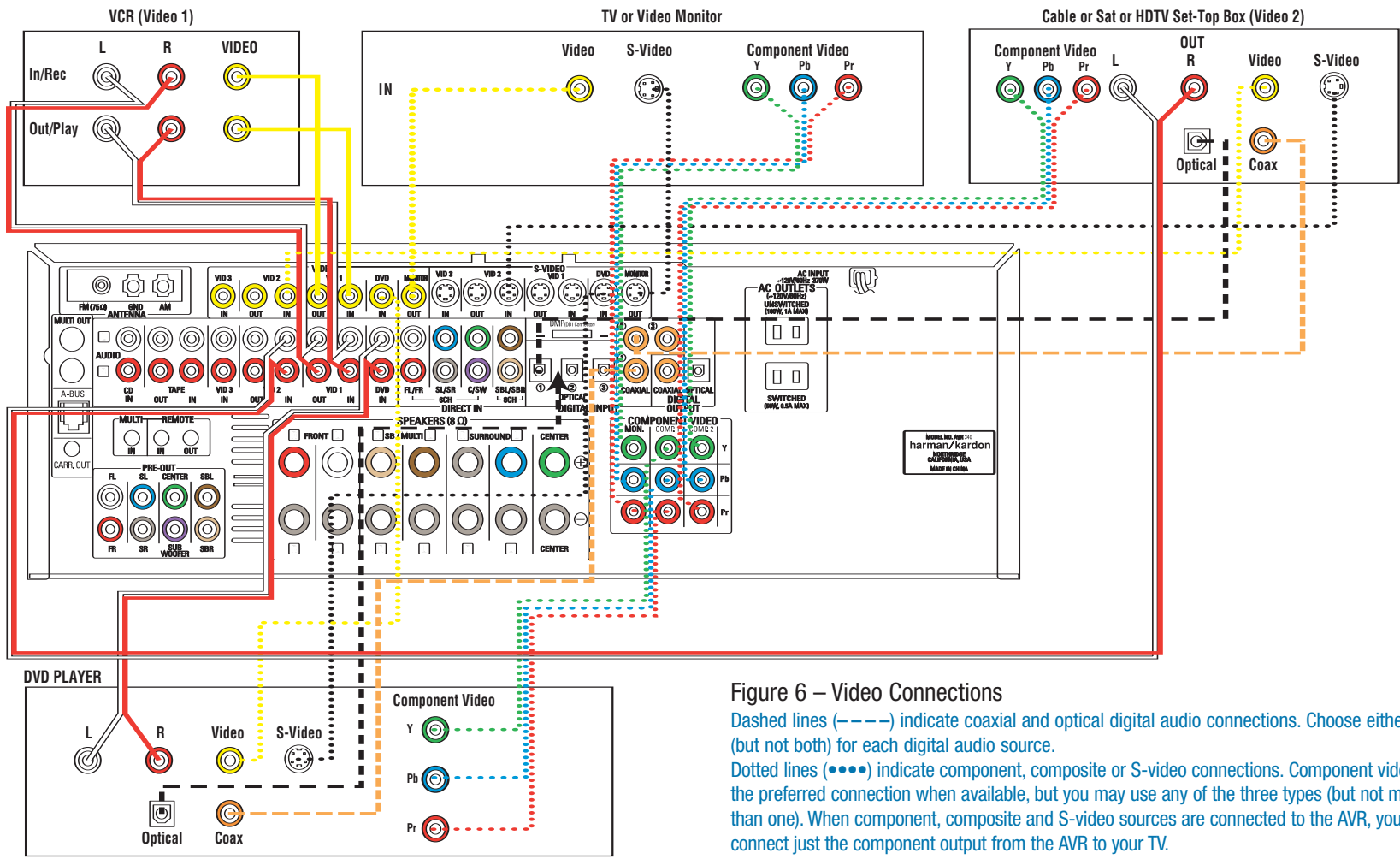

**Figure 6 – Video Connections**  
 Dashed lines (----) indicate coaxial and optical digital audio connections. Choose either type (but not both) for each digital audio source.  
 Dotted lines (.....) indicate component, composite or S-video connections. Component video is the preferred connection when available, but you may use any of the three types (but not more than one). When component, composite and S-video sources are connected to the AVR, you may connect just the component output from the AVR to your TV.

**Device Connection Options:** Recommended connections are shown in red, but connections may be made to best fit your system requirements. The Video 4, Coaxial 4 and Optical 4 inputs are on the front panel of the receiver.

Device	Input Name	Audio Input Connections	Audio Output Connections	Video Connections
CD Player	CD	CD L/R Inputs, Optical Digital 1, 2 or 3, or Coaxial Digital 1, 2 or 3	Not Required	Not Required
DVD Player	DVD	Coaxial Digital 1, 2 or 3, Optical Digital 1, 2 or 3, or DVD L/R Inputs	Not Required	Component Video 1 or DVD Composite or S-Video
VCR	Video 1	Video 1 L/R Inputs	Video 1 L/R Outputs	Video 1 Composite or S-Video Input and Output
Cable Box or Satellite Receiver	Video 2	Video 2 L/R Inputs, Optical Digital 1, 2 or 3, or Coaxial Digital 1, 2 or 3 Inputs*	Not Required	Component Video 2 or Video 2 Composite or S-Video Input
The Bridge	The Bridge DMP	The Bridge DMP Connector	Not Required	Not Required
Audio Recorder	Tape	Tape L/R Inputs, Optical Digital 1, 2 or 3**, or Coaxial Digital 1, 2 or 3** Inputs	Tape L/R Outputs, Digital Optical** or Coaxial Outputs**	Not Required
TV or Projector	Not Applicable	Not Required	Not Required	Monitor-Out Component, Composite and/or S-Video

\* Check with your cable company to determine whether digital audio is available for all channels. It may be necessary to make BOTH analog and digital connections if it is not. \*\* Digital audio recorders only.